

**RIGHT ANGLE 2 HOLES FLANGE FLOATING JACK**

**R128.360.717**

**SOLDER TYPE CABLE .085**

Series : **BMA-COM**

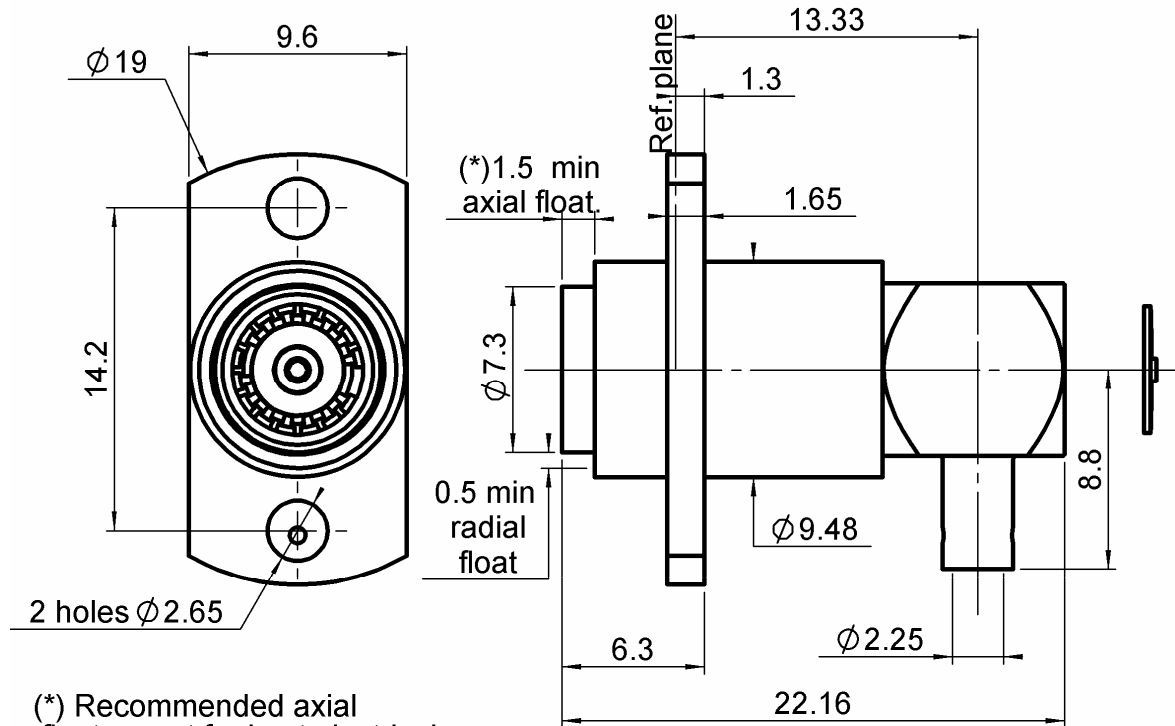

(\*) Recommended axial float mount for best electrical performance:  
0.51 +/- 0.25 mm (.020" +/- .010)

**PANEL DRILLING**

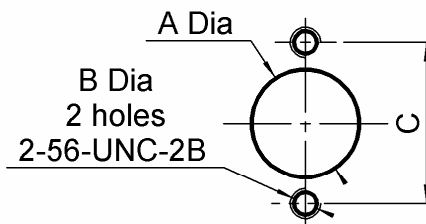

	maxi	mini
A	9.6	9.55
C	14.3	14.1

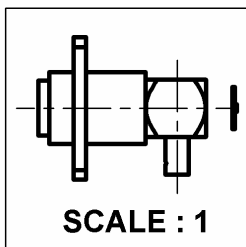

All dimensions are in mm.

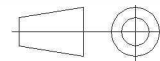

COMPONENTS	MATERIALS	PLATING (µm)
BODY	BRASS	BBR2
CENTER CONTACT	BERYLLIUM COPPER, BRASS	NPGR
OUTER CONTACT	BERYLLIUM COPPER	NPGR
INSULATOR	PTFE	
GASKET	-	
OTHERS PARTS	BRASS	BBR2
-	-	-
-	-	-

Issue : 0942      **B**

In the effort to improve our products, we reserve the right to make changes judged to be necessary.



**RIGHT ANGLE 2 HOLES FLANGE FLOATING JACK**

**R128.360.717**

**SOLDER TYPE CABLE .085**

Series : **BMA-COM**

**PACKAGING**

Standard	Unit	Other
<b>100</b>	<b>'W' option</b>	<b>Contact us</b>

**SPECIFICATION**

**ELECTRICAL CHARACTERISTICS**

Impedance		<b>50</b> Ω
Frequency		<b>0-12.4</b> GHz
VSWR	<b>1.15 +</b>	<b>0,0250</b> x F(GHz) Maxi
Insertion loss		<b>0.07</b> √F(GHz) dB Maxi
RF leakage	- (	<b>90</b> - F(GHz)) dB Maxi
Voltage rating		<b>350</b> Veff Maxi
Dielectric withstanding voltage		<b>1000</b> Veff mini
Insulation resistance		<b>5000</b> MΩ mini

**CABLE ASSEMBLY**

Stripping	a	b	c	d	e	f
mm	4,30	1,40	0,00	0,00	0,00	0,00

Assembly instruction :

Recommended cable(s)  
 RG 405  
 KS 1

Characteristics indicated on this data sheet are those that can be achieved with the highest performance cable. Intrinsic limitations of the cable may diminish the performance of the assembly

Cable retention

- pull off **136** N mini  
 - torque **NA** N.cm

**MECHANICAL CHARACTERISTICS**

Center contact retention		
Axial force – Mating end	<b>18</b>	N mini
Axial force – Opposite end	<b>18</b>	N mini
Torque	<b>NA</b>	N.cm mini

**TOOLING**

Part Number	Description	Hexagon
.	.	.
R282.740.000	SOLDERING MOUNTING	

Recommended torque		
Mating	<b>NA</b>	N.cm
Panel nut	<b>NA</b>	N.cm
Clamp nut	<b>NA</b>	N.cm
A/F clamp nut	<b>0,0000</b>	mm

**OTHER CHARACTERISTICS**

Mating life	<b>1000</b>	Cycles mini
Weight	<b>7,6660</b>	g

**It is recommended to use a service loop to facilitate the float features of the connector**

**ENVIRONMENTAL**

Operating temperature	<b>-40/+105</b>	°C
Hermetic seal	<b>NA</b>	Atm.cm3/s
Panel leakage	<b>NA</b>	

Issue : **0942**      **B**

In the effort to improve our products, we reserve the right to make changes judged to be necessary.



**RIGHT ANGLE 2 HOLES FLANGE FLOATING JACK**  
**SOLDER TYPE CABLE .085**

**R128.360.717**

Series : BMA-COM

**COMPONENTS**

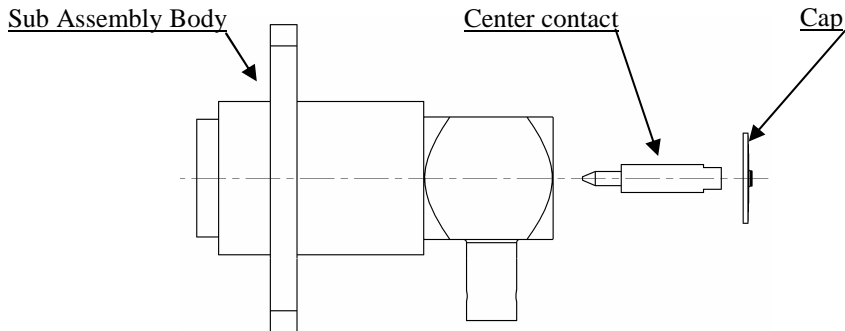

**STRIPPING DIMENSIONS**

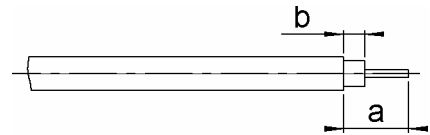

We recommend a cable thermal preconditioning before assembly

1

Strip the cable.

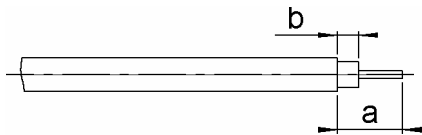

3

Place the sub-assembly into the assembly jig. Tighten it. Put three rings of solder around the cable. Solder the body onto the cable. Cleaning the solder area

2

Slide the cable into the connector until it bottoms against the body.

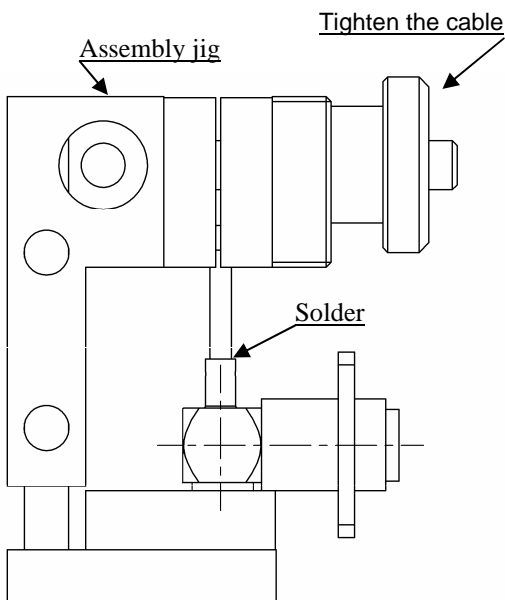

4

After cooling, remove the assembly from the jig. Solder the inner conductor. Place the cap into the body. Press on the cap flush or slightly below the surface of the body assembly.

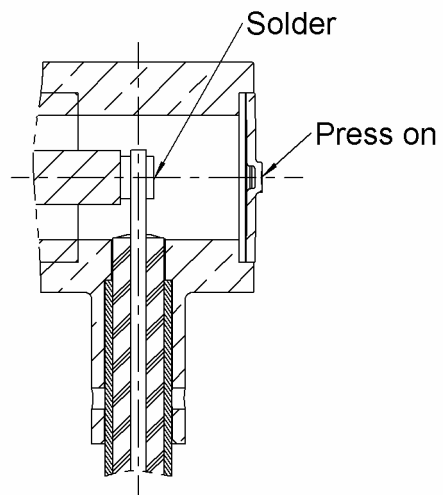

Issue : 0942 B

In the effort to improve our products, we reserve the right to make changes judged to be necessary.

